

# **DOMINATOR**<sup>®</sup>

## **INSTALLATION GUIDE**

### **SQUARE INGROUND PICKLEBALL POLE**

MODEL #: SPB-IG2

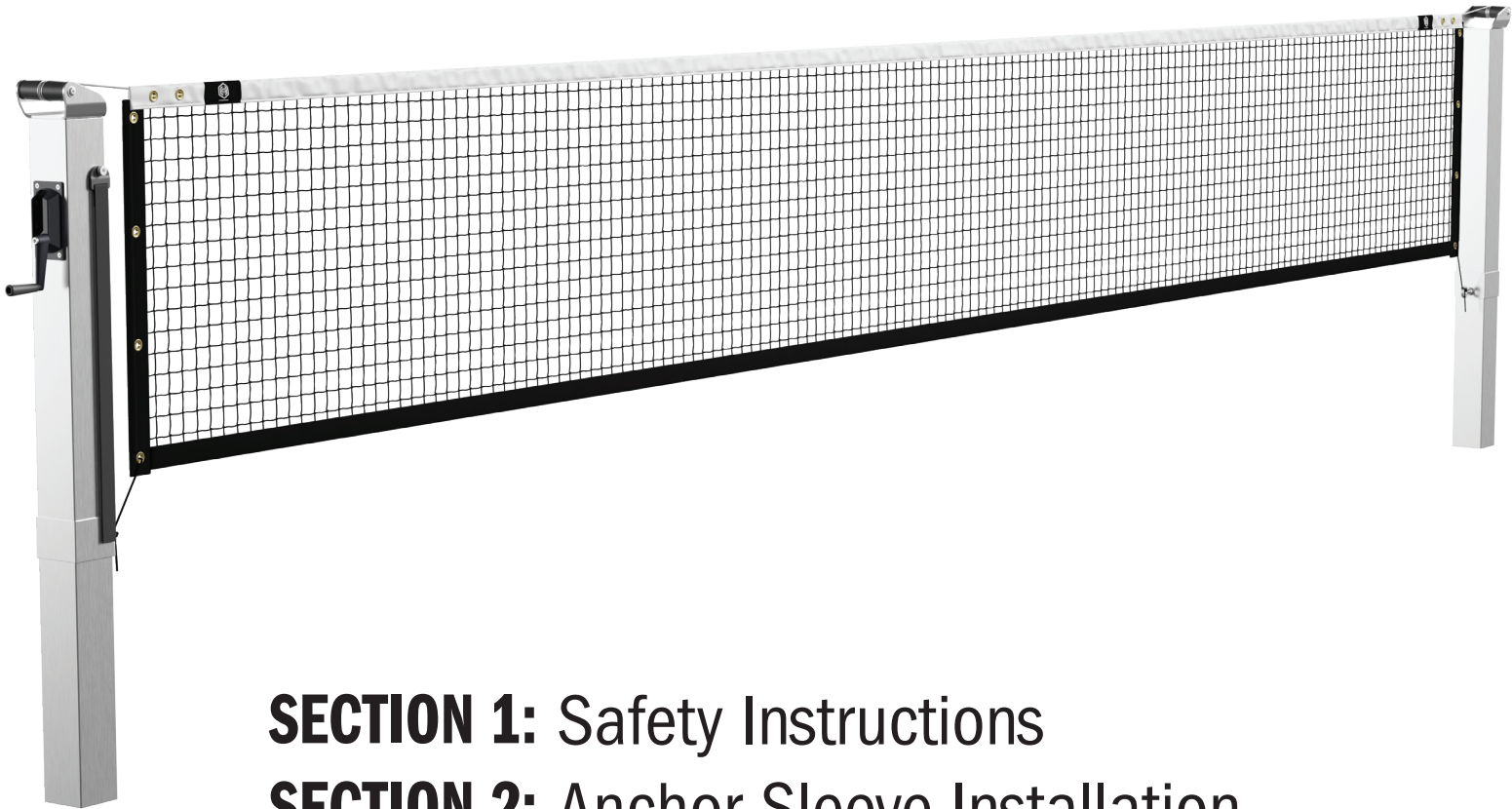

**SECTION 1:** Safety Instructions

**SECTION 2:** Anchor Sleeve Installation

**SECTION 3:** Post Installation/Net Assembly

**SECTION 4:** Warranties & Policies

# SECTION 1: SAFETY INSTRUCTIONS



## SAFETY INSTRUCTIONS



FAILURE TO FOLLOW THESE SAFETY INSTRUCTIONS MAY RESULT IN SERIOUS INJURY OR PROPERTY DAMAGE AND WILL VOID WARRANTY.

*Owner must ensure that all players know and follow these rules for safe operation of the system.*

To ensure safety, do not attempt to assemble this system without following the instructions carefully. Check the entire box and inside all packing material for parts and/or additional instruction material. Before beginning assembly, read the instructions and identify parts using the hardware identifier and parts list in the instructions. Proper and complete assembly, use, and supervision are essential for proper operation and to reduce the risk of accident or injury. A high probability of serious injury exists if this system is not installed, maintained, and operated properly.

*Most injuries are caused by misuse and/or not following instructions. Use caution when using this system.*



## WARNING



FAILURE TO FOLLOW THESE WARNINGS MAY RESULT IN SERIOUS INJURY AND/OR PROPERTY DAMAGE

- Do not climb or play on net.
- When adjusting net or moving system, keep hands and fingers away from moving parts.
- During play, do not wear jewelry (rings, watches, necklaces, etc.). Objects may entangle in net.
- Check system before each use for loose hardware and instability. Repair before each use. Never play on damaged equipment.

**DOMINATOR**

801.769.4663



**Know what's below.  
Call before you dig.**

**BEFORE** digging for the Inground Sleeve installation, contact your local call-before-you-dig phone number so you don't unintentionally dig into an underground utility line.

# SECTION 2: ANCHOR SLEEVE INSTALLATION

## DIMENSIONS

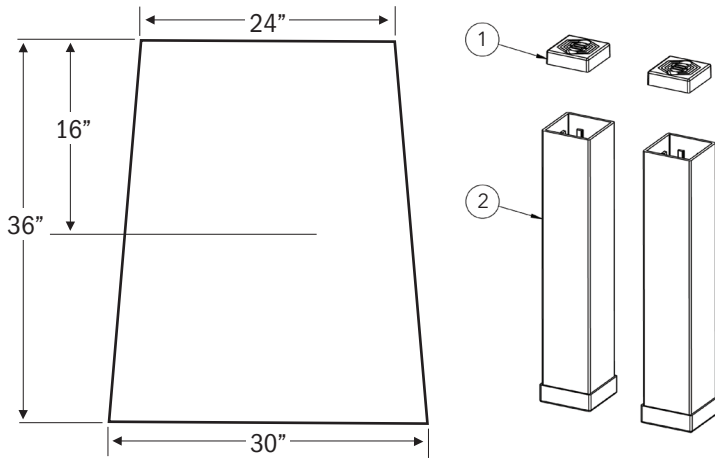

## PARTS USED

Item #	Part Number	Part Description	Qty
1	SPP3-DWG-004	Anchor Sleeve Cap	2
2	SPP3-DWG-003	Anchor Sleeve	2

## TOOLS REQUIRED

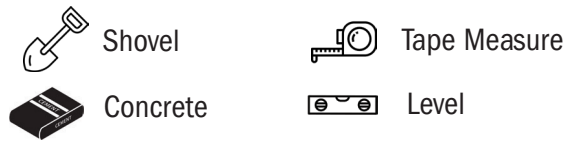

## INSTRUCTIONS

**STEP 1:** Dig two holes 20' apart to the appropriate depth and dimensions shown above. \*NOTE: These dimensions are provided as a guideline; local frost and soil conditions should be considered. Distance between inside face of both posts should be 22'.

**STEP 2:** Mix concrete. Partially fill each hole until concrete is 16" from the playing surface. See Figure 1.

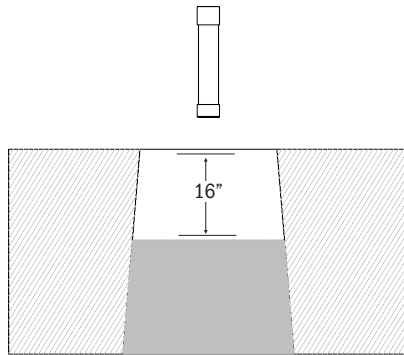

Figure 1

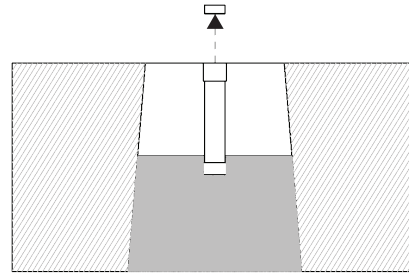

Figure 2

**STEP 3:** Remove Anchor Sleeve Cap (Item #1). Insert both Anchor Sleeves (Item #2) into the hole in the concrete. See Figure 2. The Anchor Sleeves should be 22' apart from the inside face of each post.

**STEP 4:** Using a level, ensure each Anchor Sleeve is flush with the playing surface and perfectly aligned.

**STEP 5:** Periodically check the alignment and height of the Anchor Sleeves while allowing the concrete to partial-

**STEP 6:** Replace Anchor Sleeve Cap and fill the rest of the hole with concrete. See Figure 3 and 4.

**STEP 7:** Allow concrete to cure for 72 hours before installing posts.

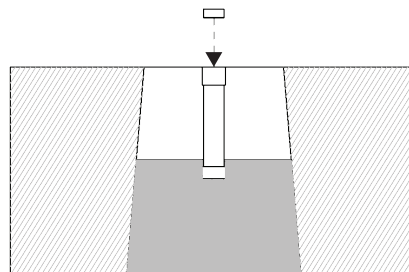

Figure 3

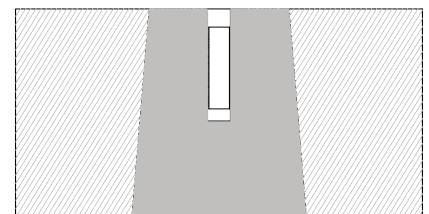
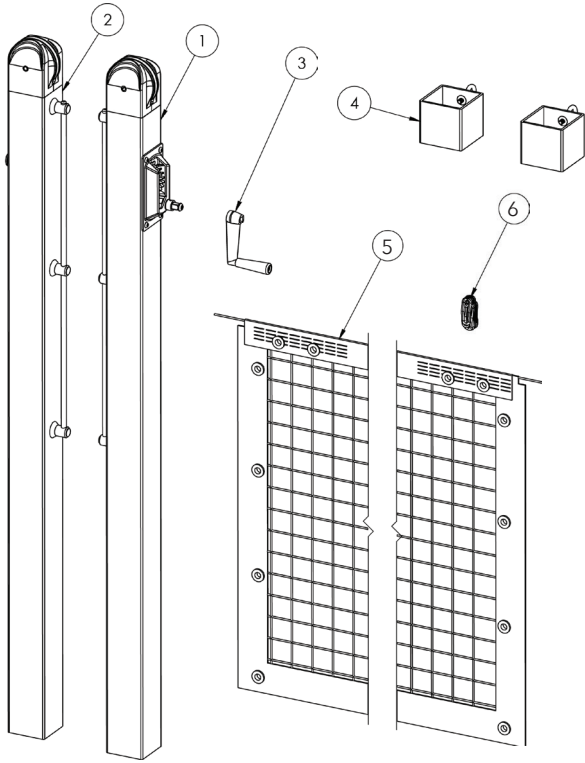

Figure 4

# SECTION 3: POST INSTALLATION/NET ASSEMBLY

\*\*\*ENSURE GROUND SLEEVE & CONCRETE HAS HAD AT LEAST 72 HOURS TO SET.

## PARTS LIST



## TOOLS REQUIRED



Item #	Part Number	Part Description	Qty
1	SPP3-ASM-001	Post A	1
2	SPP3-ASM-002	Post B	1
3	SPP3-ASM-007	Crank Handle	1
4	SPP3-ASM-008	Height Collar	2
5	RPP-DWG-031	Heavy Duty Net	1
6	RPP-DWG-032	Lacing Cord	1

## INSTRUCTIONS

- STEP 1:** Remove the screw from the Crank Handle (Item # 3) and attach the Crank Handle to Post A (Item #1). Replace the screw and tighten. See Figure 1.
- STEP 2:** Slide Height Collar (Item #4) onto each pickleball post with the eyebolts facing inward, on the same side as the lacing rod. See Figure 2.
- STEP 3:** Remove cap from the Anchor Sleeve and slide pickleball post into the sleeve with the lacing rod facing inwards, towards the other post. Repeat on other side. See Figure 3 & 4.

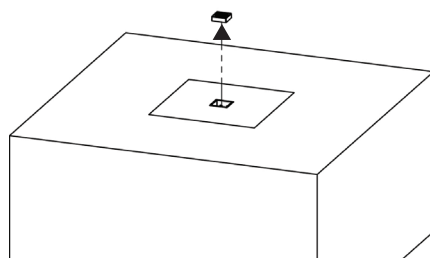
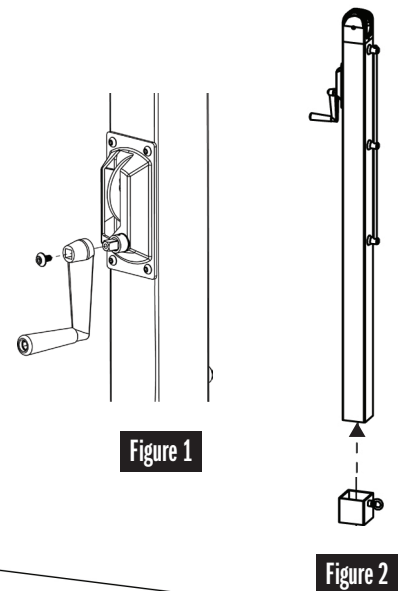

Figure 3

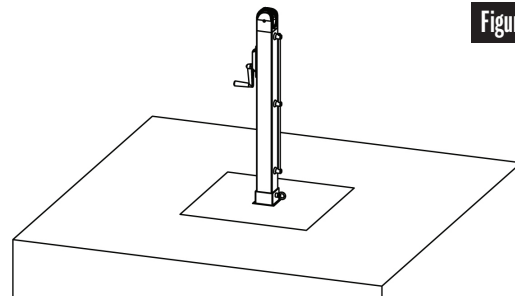

Figure 4

**STEP 4:** Loosen the eyebolt on the Height Collar and using a tape measure, adjust the height of the pickleball posts to 36". Retighten eyebolts. See Figure 5.

**STEP 5:** Unwind the Heavy Duty Net (Item #5) and lay it out across the court.

**STEP 6:** Place one end of the top cord cable over the pulley of Post B (Item # 2) and attach the cable loop around the net hook on the backside of the post. See Figure 6 & 7.

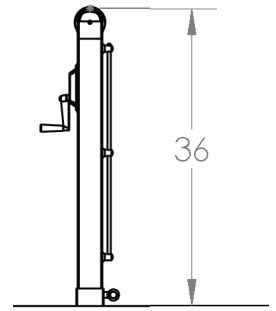

Figure 5

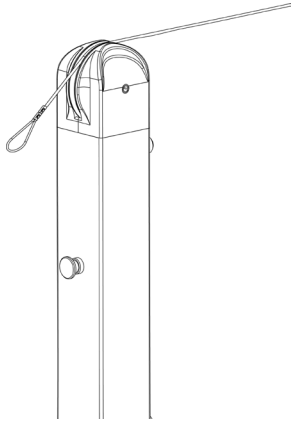

Figure 6

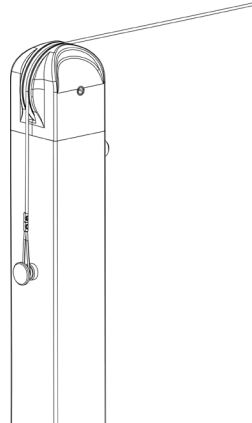

Figure 7

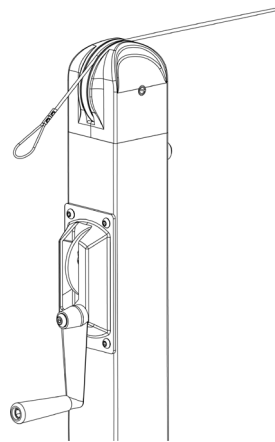

Figure 8

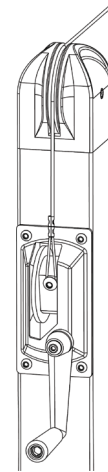

Figure 9

**STEP 7:** Place the other end of the top cord cable over the pulley of Post A and attach the loop around the screw on the crank. Tighten the screw to secure. Rotate the Crank Handle clockwise a few turns to fully tension the net. See Figure 8 & 9. Note: The center of the net should measure 34" from the top to the playing surface.

**STEP 8:** Tie a 2" knotted loop in one end of the Lacing Cord (Item #6).

**STEP 9:** Feed the other end of the lacing cord around the lacing rod, through the top grommet in the sideband of the net, and then through the 2" knotted loop.

**STEP 10:** Threading the lacing cord through both grommets in the headband of the net one way, and then back through each grommet the other way, and through the top grommet in the sideband of the net. Continue threading the lacing cord around the lacing rod and through each grommet as shown in Figure 10. Apply equal pressure as you lace the net to the post.

**STEP 11:** Tie off the cord at the bottom of the post. Repeat on the other post.

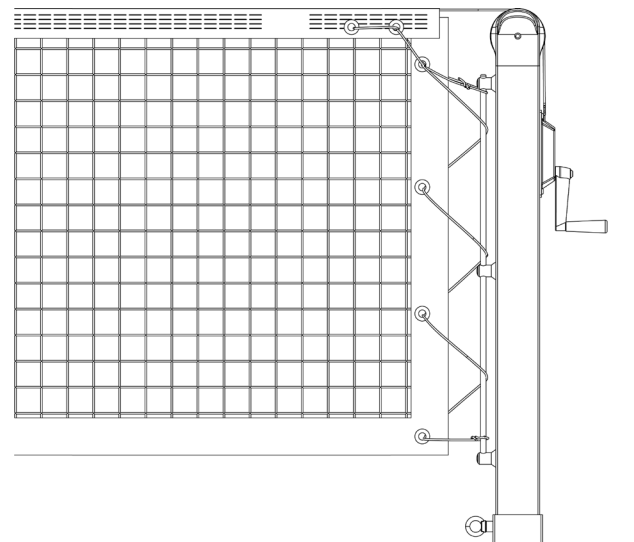

Figure 10

# SECTION 4: WARRANTIES & POLICIES

## **DOMINATOR**<sup>®</sup> STANDARD LIMITED LIFETIME WARRANTY

Subject to the limitations set forth below, HomeSports (the “Manufacturer”) warrants to the original consumer purchaser (the “Purchaser”) of the Dominator Heavy-Duty Inground Pickleball System (hereinafter referred to as the “Dominator”) that the Dominator shall be free from material defects in parts and/or workmanship that impair the use of the Dominator for so long as the Purchaser owns the Dominator.

1. This Warranty is non-transferable and is expressly limited to the repair or replacement of a defective Dominator, including any part thereof, covered under this Warranty.
2. To make a claim under this Warranty, the Purchaser must first write the Manufacturer at 405 N 880 W, Suite C, Lindon, UT 84042, to receive a Return Authorization number and/or determine specific needs.
3. The Manufacturer reserves the right to examine photographs and/or physical evidence of a Dominator claimed to be defective and to recover said Dominator pursuant to the terms of this Warranty, prior to authorization of a claim under this Warranty
4. Unless indicated otherwise by the Manufacturer, in order to determine whether a requested repair is covered under this Warranty, the Dominator must be shipped prepaid to the Manufacturer with a copy of the relevant proof of purchase. The Manufacturer will not be responsible for any loss or damage incurred in connection with the return of a Dominator or its parts to Manufacturer under this Warranty. The manufacturer will examine the Dominator so shipped and, in its sole and reasonable discretion, will determine (1) whether this Warranty covers the Dominator and, if it does, (2) whether the Dominator needs to be repaired or replaced. Any and all dealer service charges, labor costs, shipping costs, insurance, travel expenses and any other charges or costs involved in the removal, installation or replacement of a defective Dominator, including, but not limited to, any part thereof, covered under this Warranty, will be the sole responsibility of the Purchaser and must be prepaid. Any Dominator, including any part thereof, shipped to the Manufacturer “collect” will be refused.
5. THIS WARRANTY IS VOID IF THE DOMINATOR HAS BEEN DAMAGED BY ACCIDENT, UNREASONABLE USE AND/OR ABUSE, NEGLIGENCE, IMPROPER SERVICE, IMPROPER INSTALLATION OR HANDLING, FAILURE TO FOLLOW PROVIDED INSTRUCTIONS (INCLUDING WITHOUT LIMITATION USING THE DOMINATOR AT PROHIBITED HEIGHT LEVELS), SHIPPING, VANDALISM, ACTS OF GOD, ENVIRONMENTAL FACTORS, ALTERATION OF THE DOMINATOR, OR ANY OTHER EVENTS BEYOND THE CONTROL OF THE MANUFACTURER OR OTHER CAUSES NOT ARISING OUT OF DEFECTS IN MATERIAL OR WORKMANSHIP.
6. USING THE DOMINATOR FOR OTHER THAN RESIDENTIAL USE WILL ALSO VOID THIS WARRANTY.
7. HANGING FROM THE NET WILL ALSO VOID THIS WARRANTY: Nets are not warranted for any defects other than workmanship. Torn back plates, damaged springs, bent rings, damaged eyebolts and torn or distorted net supports result from hanging are not warranted.
8. THIS WARRANTY DOES NOT COVER SCRATCHING OR SCUFFING OF THE DOMINATOR THAT MAY RESULT FROM NORMAL USAGE. THIS WARRANTY ALSO DOES NOT COVER RUSTING PARTS, FADING PAINT, CRACKS THAT DO NOT AFFECT THE FUNCTIONALITY OF THE PRODUCT, OR OTHER DAMAGE CAUSED BY WEATHER OR CLIMATE CONDITIONS OR EXPOSURE TO CORROSIVES SUCH AS SALTS, PESTICIDES, ET
9. This warranty gives the Purchaser specific legal rights, and such Purchaser may also have other rights which vary from state to state.
10. THIS WARRANTY IS GIVEN EXPRESSLY IN LIEU OF ALL OTHER EXPRESS WARRANTIES. ANY IMPLIED WARRANTY ARISING OUT OF THE SALE OF THE DOMINATOR, INCLUDING, BUT NOT LIMITED TO, THE IMPLIED WARRANTIES OF MERCHANTABILITY AND FITNESS FOR A PARTICULAR PURPOSE, IS LIMITED IN DURATION TO THE DURATION OF THIS WARRANTY.
11. Some states do not allow limitations on how long an implied warranty lasts, so the above limitation may not apply to certain Purchasers.
12. THE REMEDY OF REPAIR OR REPLACEMENT STATED ABOVE SHALL BE THE PURCHASER'S EXCLUSIVE REMEDY. THE MANUFACTURER DOES NOT ASSUME OR AUTHORIZE ANY PERSON OR REPRESENTATIVE TO ASSUME ON ITS BEHALF ANY OTHER LIABILITY IN CONNECTION WITH THE SALE OF A DOMINATOR. THE MANUFACTURER SHALL NOT BE LIABLE FOR (A) ANY DAMAGES OR EXPENSES THAT MAY OCCUR, INCLUDING, BUT NOT LIMITED TO, INCIDENTAL, SPECIAL OR CONSEQUENTIAL DAMAGES, ARISING OUT OF OR IN CONNECTION WITH THE DELIVERY, INSTALLATION, USE, PERFORMANCE AND/OR REMOVAL OF THE DOMINATOR (INCLUDING, BUT NOT LIMITED TO, DAMAGE TO CONCRETE OR THE PURCHASER'S YARD); (B) ANY OTHER CLAIM ARISING FROM NEGLIGENCE, STRICT LIABILITY, OR BREACH OF CONTRACT REGARDING THE DOMINATOR; OR © OTHER DAMAGES WITH RESPECT TO ANY ECONOMIC LOSS, LOSS OF PROPERTY, LOSS OF ENJOYMENT OF USE, COSTS OF INSTALLATION AND/OR REMOVAL, OR OTHER CONSEQUENTIAL DAMAGES FOR BREACH OF ANY EXPRESS OR IMPLIED WARRANTY COVERING THE DOMINATOR.
13. Some states do not allow the exclusion or limitation of incidental or consequential damages, so the above limitation or exclusion may not apply to certain Purchasers.
14. While the Manufacturer has made attempts to ensure that the Dominator is safe to use, freedom from injury cannot be guaranteed. The Purchaser assumes all risk of injury resulting from the use of the Dominator. All Dominators are sold subject to this condition, and no representative of the Manufacturer may waive or change this policy.



# **DOMINATOR**

## **STANDARD SHIPPING POLICY**

This Return Policy applies to the purchase of the Dominator® Heavy-Duty Inground Pickleball System (hereinafter referred to as the “Dominator”) by the original consumer purchaser (“you” or the “Purchaser”) from Leap Innovations (the “Manufacturer”).

1. Any offer for free shipping by the Manufacturer applies ONLY to shipments within the domestic 48 continental United States. Please contact us at 1-877-705-6556 for a shipping quote for deliveries to Alaska, Hawaii, Canada, Mexico, or other locations outside of the United States.
2. If the shipping address is changed during shipping, additional charges may apply.
3. Shipping dates are approximate and Manufacturer does not guarantee estimated delivery dates. Manufacturer is not liable under any circumstances for any delay in shipment or delivery.
4. It is your responsibility to verify the delivery for correctness. You should confirm the correct number of boxes has been delivered to you.
5. You should also carefully inspect all items prior to installing for damage during transit and take photographs of the damage.
6. DO NOT REFUSE DELIVERY IF THE DOMINATOR, OR ANY PORTION THEREOF, IS DAMAGED. Simply note the damage on the delivery receipt and contact us at 801-768-4663 to receive a replacement part.
7. If a certain part, such as the net, is damaged, you may still keep and install the additional working parts while the replacement part is being delivered.
8. Please note, if you live down a road or driveway that the delivery truck cannot traverse, the delivery will not be completed. You may be required to pick up the order from the nearest carrier terminal.
9. Any order returned to Manufacturer marked undeliverable or similar is subject to a 15% restocking fee and any shipping charges incurred by Manufacturer for the initial shipment to the Purchaser will be charged to the Purchaser.

# **DOMINATOR**

## **STANDARD RETURN POLICY**

This Return Policy applies to the purchase of the Dominator® Heavy-Duty Inground Pickleball System (hereinafter referred to as the “Dominator”) by the original consumer purchaser (“you” or the “Purchaser”) from Leap Innovations (the “Manufacturer”).

1. The Purchaser may cancel an order before shipment and receive a full refund of the amount paid. Orders are normally shipped within 48 business hours and are sometimes shipped the same day.
2. The Purchaser may return an order within 7 days of receipt of the Dominator by the Purchaser to receive a partial refund. All returns are subject to a 15% re-stocking fee. The Purchaser is responsible for initial shipping fees upon return of the Dominator and any offer for free shipping is surrendered upon return. Except as provided in
3. Manufacturer’s limited lifetime warranty, Manufacturer has sole discretion to reject a request for cancellation or return.
4. The Dominator must be unused, in the original shipping boxes and packaging, to be eligible for a refund.
5. Notwithstanding the above paragraphs, Purchaser shall have no right to cancel or return custom-made products.
6. To make a return, the Purchaser must first contact the Manufacturer at 1-877-705-6556 to receive a Return Authorization number and/or determine specific needs. YOU MUST HAVE A RETURN AUTHORIZATION NUMBER OR YOUR RETURN WILL NOT BE PROCESSED.
7. The Purchaser must ship the Dominator to the Manufacturer with proof of purchase. Any and all dealer service charges, labor costs, shipping costs, insurance, travel expenses and any other charges or costs involved in the return of a Dominator, will be the sole responsibility of the Purchaser and must be prepaid. The Manufacturer will not be responsible for any loss or damage incurred in connection with the return of a Dominator or its parts to Manufacturer. Any Dominator, including any part thereof, shipped to the Manufacturer “collect” will be refused.